



DHV CONSULTANTS &
DELFT HYDRAULICS with
HALCROW, TAHAL, CES,
ORG & JPS

VOLUME 6
WATER QUALITY SAMPLING

FIELD MANUAL

Table of Contents

1	LABORATORY PREPARATIONS FOR SAMPLING	1-1
1.1	SAMPLERS	1-1
1.2	SAMPLE CONTAINERS	1-1
1.3	REAGENT SOLUTIONS	1-3
1.4	INSTRUMENTS	1-3
2	CHECK LIST FOR FIELD VISIT	2-1
3	COLLECTING THE SAMPLE	3-1
3.1	SAMPLE CONTAINERS	3-1
3.2	COLLECTING THE SAMPLE	3-1
3.3	SPECIAL SAMPLES	3-3
3.4	SAMPLE IDENTIFICATION FORMS	3-4
3.5	SAMPLE LABELLING	3-6
3.6	SAMPLE PRESERVATION AND TRANSPORT	3-6
4	STANDARD ANALYTICAL PROCEDURES – FIELD DETERMINATIONS	4-1
4.1	GENERAL	4-1
4.2	COLOUR	4-1
4.3	ODOUR	4-1
4.4	TEMPERATURE	4-2
4.5	ELECTRICAL CONDUCTIVITY	4-2
4.6	pH	4-4
4.7	DISSOLVED OXYGEN	4-4
5	GUIDELINES ON STANDARD ANALYTICAL PROCEDURES	5-1
	ODOUR	5-2
	TEMPERATURE	5-3
	ELECTRICAL CONDUCTIVITY	5-4
	pH	5-7
	DISSOLVED OXYGEN	5-9

1 LABORATORY PREPARATIONS FOR SAMPLING

Many preparations for a sampling campaign need to be made at the laboratory where the bulk of the analyses are being carried out, i.e. Level II/III+ laboratory. In some cases, these preparations can be done at a Level I laboratory, if samples are only being collected for analysis of the 'field parameters'.

Laboratory preparations must be made for:

- Sampler(s)
- Sample containers
- Reagent solutions
- Instruments
- Ice box

1.1 SAMPLERS

At least two types of samplers will be needed in the field: general purpose sampler and Dissolved Oxygen sampler. The samplers should be cleaned and rinsed. Samplers should also be briefly checked for functioning, closing caps if applicable, and condition of the rope.

1.2 SAMPLE CONTAINERS

The sample containers for the water quality sampling need to be prepared in the laboratory and given to the person conducting sampling.

The number of containers and the type of containers needed for the water quality sampling needs to be determined based on the number of sites to sample and the parameters selected for monitoring. In the design-phase of the monitoring programme, the sampling locations, and the type of sampling location (baseline, trend, surveillance, etc.) is determined, which gives the frequency of sampling and the parameters.

In order to cover the range of parameters which need to be sampled and analysed, a variety of sample containers are used. Table 1.1 gives the required type of container and the suggested volume of sample for most common parameters.

Bottles which are to be used for the samples must be thoroughly washed and then rinsed with distilled water before use. Bottles which are to be used for microbiological samples must be thoroughly washed and sterilised before use. Sterilising can be carried out by placing the bottles in an autoclave at 121°C for fifteen minutes or, if the caps of the bottles do not contain plastic or rubber materials, in an oven at 170°C for at least two hours. Bottles to be used for pesticides samples are to be rinsed with organic solvent (e.g. hexane) prior to use. This should be done in the laboratory.

All bottles should be checked to see if the (screw)caps and seals close properly. Labels for the sample bottles should be prepared or special pens for labelling the bottles should be used. Making a list of sample containers per site will ensure that the right number and type of containers are brought to the field. Always bring a few extra in case of unforeseen events.

Parameter Group	Parameter	Sample Container (See note below)	Sample Pre-treatment (See note below)
General	Temperature	On-site analysis	On-site analysis
	Suspended Solids	1	None*
	Conductivity	On-site analysis	On-site analysis
	pH	On-site analysis	On-site analysis
	Dissolved Oxygen	2	7
	Dissolved Solids	1	None*
Nutrients	Ammoniacal Nitrogen	3	8
	Total Oxidised Nitrogen	3	8
	Total Phosphorus	4	None*
Organic Matter	Chemical Oxygen Demand	3	8
	Biochemical Oxygen Demand	2	4°C, Dark
Major Ions	Sodium	3	None*
	Potassium	3	None*
	Calcium	3	None*
	Magnesium	3	None*
	Carbonates and Bicarbonates	1	None*
	Chloride	1	None*
	Sulphate	1	None*
Other Inorganics	Silica	1	None*
	Fluoride	1	None*
	Boron	1	None*
Metals	Cadmium	3	9
	Mercury	4	9
	Zinc	3	9
Organics	Pesticide (Indicator)	5	4°C, Dark
	Synthetic Detergents	1	None*
	Organic Solvents	1	4°C, Dark
	Phenols	5	8
Microbiological	Total coliforms	6	4°C, Dark
Biological	Chlorophyll 'a'	1	4°C, Dark
<p>NOTES:</p> <p><i>Containers:</i></p> <ol style="list-style-type: none"> 1000 millilitre polyethylene bottle Special BOD bottle (normally 300 millilitre) 500 millilitre polyethylene bottle 100 millilitre glass bottle 1000 millilitre glass (or Teflon) bottle with Teflon lined caps Strong thick-walled, screw-capped glass bottle (300 millilitre capacity). Only good quality will maintain a good seal after multiple sterilisations in an autoclave <p><i>Preservation:</i></p> <ol style="list-style-type: none"> Samples for dissolved oxygen analysis are fixed by adding 1 ml of manganous sulphate solution, 1 ml of alkaline iodide-azide solution and mixing. Care should be taken to ensure that no air is added to the sample during this process. Samples should be acidified with 2 ml of concentrated sulphuric acid Samples should be acidified with 2 ml of concentrated nitric acid. <p>*None: Ideally, <i>all</i> samples should be kept cool and in the dark after collection. If this is not possible, then at least samples for BOD, coliforms, chlorophyll, pesticides and other organics that are likely to volatilize MUST be kept at 4°C, and dark. Remaining samples can have no preservation.</p>			

Table 1.1: Water Quality Parameters - Sampling Containers and Pre-treatments Required

1.3 REAGENT SOLUTIONS

For some of the field analyses, reagent solutions are necessary for the analysis. All necessary reagent solutions should be prepared in the laboratory and brought to the field by the sample collector. Alternatively, reagent solutions can be kept at a Level I laboratory near the sampling site, if the 'field analyses' are going to be made there. In all cases, sample preservatives and DO fixing solutions *must* be brought to the field and added to the samples immediately after collection.

Refer to the '*Guidelines on Standard Analytical Procedures for Water Analyses*' for detailed procedures on preparation of reagents. Relevant procedures are given in Chapter 5.

For analysis of pH, buffer solutions are necessary to standardise the pH meter: Buffer solutions should be prepared in the laboratory, or purchased, for pH = 4, pH = 7, and pH = 9.

For analysis of Electrical Conductivity, standard potassium chloride solution, KCl (0.01M) is needed to standardise the conductivity meter.

For analysis of dissolved oxygen, DO fixing chemicals are necessary:

- manganous sulphate solution
- alkaline iodide-azide solution
- concentrated sulphuric acid

DO fixing chemicals should be kept in glass or PE bottles. If a glass bottle is used, a rubber stopper must be used for the alkaline reagent. A glass pipette or dropper of 2 ml capacity is needed to add the fixing chemicals to the samples.

Chemicals for DO titration must also be brought to the field, or must be available at the Level I laboratory where the titration will be done:

- Starch indicator
- Standard sodium thiosulphate titrant, 0.025M (0.025N). This needs to be standardised with potassium bi-iodate solution 0.0021M (0.0126N).

For preservation of certain samples, concentrated nitric acid and concentrated sulfuric acid are needed.

A supply of distilled water is needed for rinsing equipment.

1.4 INSTRUMENTS

Some instruments and equipment are necessary to make the field analyses. Instruments and equipment must be brought to the field, or must be available at the Level I laboratory where the 'field analyses' will be done. *Temperature should always be measured in the field:*

- For measurement of Temperature, a (mercury) thermometer or thermistor is needed.
- For analysis of Electrical Conductivity, a conductivity meter is needed.
- For analysis of pH, a pH meter is needed.
- For analysis of DO, equipment for a DO titration is necessary: Erlenmeyer flask and burette

Note: it is possible that instead of separate meters for temperature, pH and conductivity, there is a single instrument with different probes which will measure all three parameters.

A supply of batteries and standard spare parts should also be carried along with the field instruments.

2 CHECK LIST FOR FIELD VISIT

Table 2.1 contains a list of items which should be checked before starting on a sampling mission. At least one day before sampling, make sure that all the arrangements are made as per the check list.

Make sure that you know how to reach sampling site(s). Take help of location map for each site which shows the sample collection point with respect to prominent landmarks in the area. In case there is any deviation in the collection point, record it on the sample identification form giving reason.

Note that depending on the local conditions, water body, analysis requirements, etc., not all items on the check list may be necessary. Other items, not listed, may be required. The field operation may make his or her own personal checklist based on Table 2.1.

Decide on the number of each item that would be required depending on the number of samples to be collected. It is always safer to carry a few numbers in excess.

If for any reason the laboratory conducting analyses is different from the laboratory preparing sample bottles, ensure that the concerned laboratory is informed of the programme and ready to receive samples, particularly those which would need immediate attention.

<ul style="list-style-type: none"> Itinerary for the trip (route, stations to be covered, start and return time) 	<ul style="list-style-type: none"> Personnel and sample transport arrangement
<ul style="list-style-type: none"> Area map 	<ul style="list-style-type: none"> Sampling site location map
<ul style="list-style-type: none"> Icebox filled with ice or icepacks 	<ul style="list-style-type: none"> Weighted bottle sampler
<ul style="list-style-type: none"> DO sampler 	<ul style="list-style-type: none"> Rope
<ul style="list-style-type: none"> BOD bottles 	<ul style="list-style-type: none"> Sample containers
<ul style="list-style-type: none"> Special sample containers: bacteriological, heavy metals, etc. 	<ul style="list-style-type: none"> DO fixing and titration chemicals and glassware
<ul style="list-style-type: none"> Sample preservatives (e.g. acid solutions) 	<ul style="list-style-type: none"> Thermometer
<ul style="list-style-type: none"> Tissue paper 	<ul style="list-style-type: none"> Other field measurement kit, as required
<ul style="list-style-type: none"> Sample identification forms 	<ul style="list-style-type: none"> Labels for sample containers
<ul style="list-style-type: none"> Field notebook 	<ul style="list-style-type: none"> Pen / pencil / marker
<ul style="list-style-type: none"> Soap and towel 	<ul style="list-style-type: none"> Match box
<ul style="list-style-type: none"> Spirit lamp 	<ul style="list-style-type: none"> Torch
<ul style="list-style-type: none"> Drinking water 	<ul style="list-style-type: none"> Knife
	<ul style="list-style-type: none"> Gloves and eye protection

Table 2.1: Checklist for field visit

3 COLLECTING THE SAMPLE

3.1 SAMPLE CONTAINERS

The sample containers needed for a sampling campaign are prepared by the laboratory and given to the person collecting samples. An overview of the types of containers and preservation is given in Table 3.1. More detailed information on the specific containers needed for each parameter is given in Table 1.1.

	Analysis	Container	Volume (mL)	Preservation
0	on site analysis	PE bowl or container	±200	-
1	General (SS, TDS, major ions, chlorophyll-a)	Glass, PE	1000	-
2	COD, NH ₃ , NO ₂ -+NO ₃ -	Glass, PE	500	H ₂ SO ₄ , pH <2
3	P	Glass	100	-
4	DO	special BOD bottle	300	DO fixing
5	BOD	Glass, PE	1000	4°C, Dark
6	Coliforms	Glass, PE, Sterilised	300	4°C, Dark
7	Heavy metals (Cd, Zn)	Glass, PE	500	HNO ₃ , pH <2
8	Mercury	Glass	1000	HNO ₃ , pH <2
9	Pesticides	Glass, Teflon	1000	4°C, Dark

Table 3.1: Container types and volumes needed for sampling

3.2 COLLECTING THE SAMPLE

Samples will be collected from the selected site at the intended date and time of sampling. At that time the collector should collect the required volumes of water in the allocated container(s). Usually, unless specified otherwise, the samples to be collected are grab-samples taken from the well-mixed section of the main current.

In the event that the monitoring is meant to check the water quality for a specific water use function (i.e. surveillance monitoring), then the sample should be collected at the point of use. For example, if water quality monitoring is meant to check bathing water quality, a sample should be collected at the bathing location. For water quality monitoring to check drinking water quality, a sample should be collected at the point of water abstraction.

The simplest form of a water sampling device is a bottle or bucket attached to a string. However, this will not sink easily below the water surface. To lower a plastic or glass bottle in a body of water it is necessary to use a bracket or holder of sufficient weight to overcome the buoyancy of the bottle and allow it to sink rapidly to the required depth, usually 20-30 cm below the water surface. Such a holder designed to contain a one or two-litre bottle is shown in Figure 3.1.

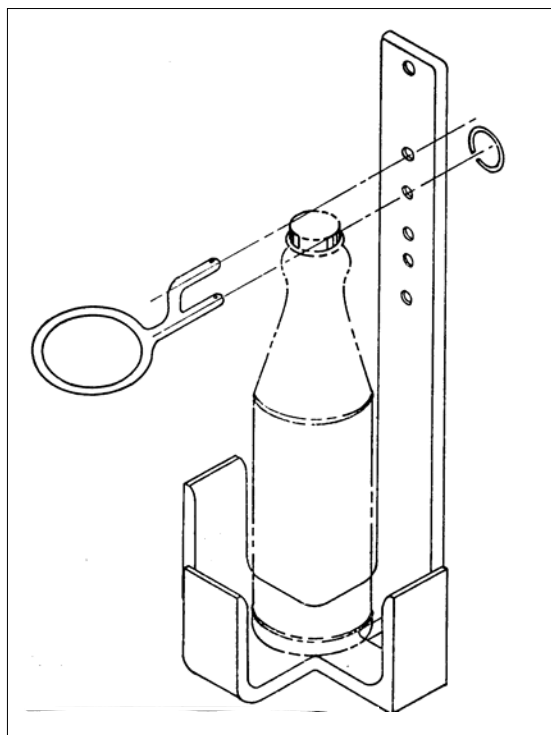

Figure 3.1:
Sample bottle holder for sampling

Where feasible a sample may be collected by holding the sample bottle in hand and submerging it. Collect the sample from the well-mixed section of the river, approximately 20-30 cm below the water surface (see Figure 3.2) . Care must be taken not to catch any floating material or bed material into the container. If the water is less than 40cm, the sample should be collected at half the actual water depth. If possible, sampling from shallow waters (less than 40cm) should be prevented by moving, within the site, to a deeper part of the river or stream.

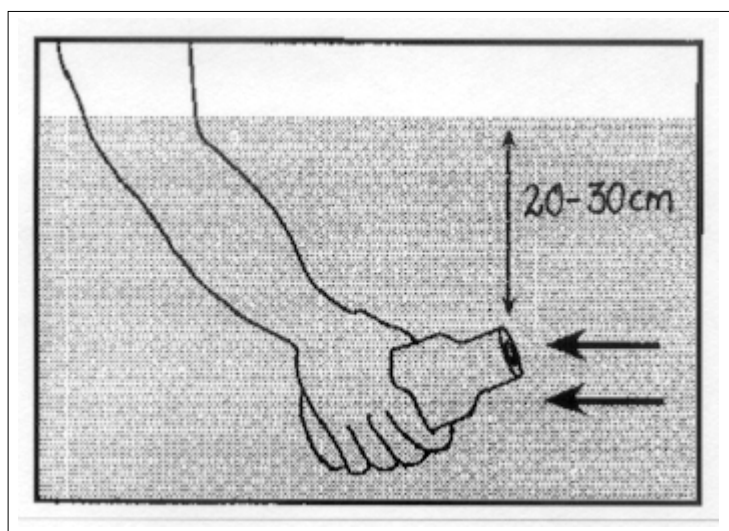

Figure 3.2:
Collecting a sample from surface water

Samples from reservoir sites will be collected from the outgoing canal, power channel or water intake structure, in case water is pumped. When there is no discharge in the canal, sample will be collected from the upstream side of the regulator structure, directly from the reservoir.

Rinse the sample container three times with the sample before it is filled.

Leave a small air space in the bottle to allow mixing of sample at the time of analysis.

3.3 SPECIAL SAMPLES

Dissolved Oxygen

Collecting a sample for Dissolved Oxygen analysis requires special sampling equipment: a purpose-built dissolved oxygen sampler, for collection of undisturbed samples from surface waters (Figure 3.3). This sampler prevents air bubbles from entering into the sample and changing the dissolved oxygen concentration of the sample.

To collect the sample, insert the special ground glass-stoppered bottle (a 'BOD bottle') into the DO sampler. Submerge the sampler, such that water enters the BOD bottle directly by means of a dip-pipe thus displacing all air from the bottle. Retrieve the sampler after it is full, and then immediately seal the full bottle with a ground glass stopper.

The Dissolved Oxygen sample needs to be 'fixed' immediately after collection as described in Chapter 3.6.

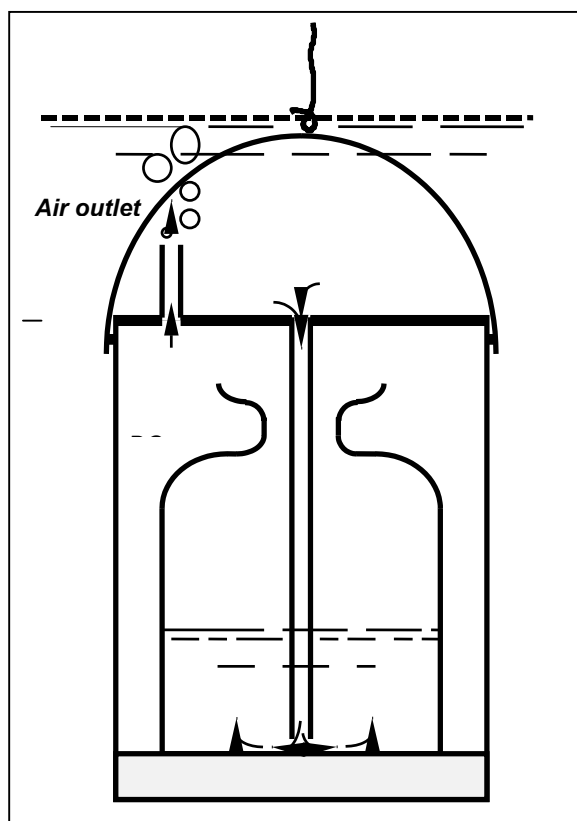

Figure 3.3:
Dissolved oxygen sampler (with one BOD-bottle).

Composite Samples

In most cases, a composite sample is a combination of equal volumes of a number of grab samples collected at the same location at different times. The volumes of the individual grab samples making the composite sample may also be varied in proportion to the flow in the river at the time of sampling. In such a case it is called a flow weighted composite sample.

Composite samples may be required only in special cases for calculation of mass flux in rivers when the quality of water is suspected to change over short periods of time. It is, however, a routine practice when wastewater streams are to be characterised.

Integrated Sample

An integrated sample is a mixture of grab samples collected simultaneously at different locations across the width of the river and/or at different depths. The need for an integrated sample may occur for very wide and deep rivers where the quality of water may vary across its width and depth.

3.4 SAMPLE IDENTIFICATION FORMS

The sample identification form provides a record of all important information concerning the sample collected. Complete the sample identification form at each monitoring site, detailing the samples that are collected at that site. Note that if more than one bottle is filled at a site, for different types of analyses, this is to be registered on the same form.

Local conditions, such as weather, human activity on the banks, state of water body, etc., at the sampling site should be recorded on the form, at the time of sampling. Such information may be useful in analysis of data.

The form for identifying the sample and recording the field measurements and site conditions is given in Figure 3.4.

Sample identification forms should be given to the laboratory analyst together with the samples. The forms should all be kept in a master file at the level II or II+ laboratory where the samples are analysed.

Sample code												
Observer				Agency				Project				
Date		Time		Station code								
Parameter Code	Container				Preservation				Treatment			
	Glass	PVC	PE	Teflon	None	Cool	Acid	Other	None	Decant	Filter	
(1) Gen												
(2) Bact												
(3) BOD												
(4) COD, NH ₃ , NO ₃ ⁻												
(5) H. Metals												
(6) Tr. Organics												
Source of sample												
Waterbody	Point			Approach		Medium		Matrix				
<input type="checkbox"/> River <input type="checkbox"/> Drain <input type="checkbox"/> Canal <input type="checkbox"/> Reservoir	<input type="checkbox"/> Main current <input type="checkbox"/> Right bank <input type="checkbox"/> Left bank			<input type="checkbox"/> Bridge <input type="checkbox"/> Boat <input type="checkbox"/> Wading		<input type="checkbox"/> Water <input type="checkbox"/> Susp matter <input type="checkbox"/> Biotap <input type="checkbox"/> Sediment		<input type="checkbox"/> Fresh <input type="checkbox"/> Brackish <input type="checkbox"/> Salt <input type="checkbox"/> Effluent				
Sample type	<input type="checkbox"/> Grab <input type="checkbox"/> Time-comp <input type="checkbox"/> Flow-comp <input type="checkbox"/> Depth-integ <input type="checkbox"/> Width-integ											
Sample device	<input type="checkbox"/> Weighted bottle <input type="checkbox"/> Pump <input type="checkbox"/> Depth sampler											
Field determinations												
Temp	°C	PH	EC				µmho/cm		DO	mg/L		
Odour Code	(1) Odour free (2) Rotten eggs (3) Burnt sugar (4) Soapy (5) Fishy		(6) Septic (7) Aromatic (8) Chlorinous (9) Alcoholic (10) Unpleasant				Colour code	(1) Light brown (2) Brown (3) Dark brown (4) Light green (5) Green		(6) Dark green (7) Clear (8) Other (specify)		
Remarks												
Weather	<input type="checkbox"/> Sunny <input type="checkbox"/> Cloudy <input type="checkbox"/> Rainy <input type="checkbox"/> Windy											
Water vel. m/s	<input type="checkbox"/> High (> 0.5) <input type="checkbox"/> Medium (0.1-0.5) <input type="checkbox"/> Low (< 0.1) <input type="checkbox"/> Standing											
Water use	<input type="checkbox"/> None <input type="checkbox"/> Cultivation <input type="checkbox"/> Bathing & washing <input type="checkbox"/> Cattle washing <input type="checkbox"/> Melon/vegetable farming in river bed											

Figure 3.4: Sample identification form for surface water samples

3.5 SAMPLE LABELLING

Label the sample container properly, preferably by attaching an appropriately inscribed tag or label. Alternatively, the bottle can be labelled directly with a water-proof marker. Information on the sample container or the tag should include:

- sample code number (identifying location)
- date and time of sampling
- source and type of sample
- pre-treatment or preservation carried out on the sample
- any special notes for the analyst
- sampler's name

3.6 SAMPLE PRESERVATION AND TRANSPORT

Preserve the collected samples as specified in Table 3.1 and Table 1.1.

Samples for BOD and bacteriological analyses should be stored at a temperature below 4°C and in the dark as soon as possible after sampling. In the field this usually means placing them in an insulated cool box together with ice or cold packs. Once in the laboratory, samples should be transferred as soon as possible to a refrigerator.

Samples for DO measurement should be chemically fixed immediately after collection:

- a. With the stopper in the bottle, drain any liquid in the flared lip of the BOD bottle containing the sample.
- b. Remove stopper and add 1 mL of $MnSO_4$ followed by 1 mL alkali-iodide-azide reagent. Hold the pipette tip just below the liquid surface touching the side of the bottle. Wash the pipette before returning to the reagent bottles.
- c. Stopper the bottle carefully to exclude air bubbles. Mix by inverting the bottle a few times.
- d. Allow the brown manganese hydroxide floc (white floc indicates absence of DO) to settle approximately to half the bottle volume, then add 1.0 mL conc H_2SO_4 and re-stopper. Mix by inverting several times until dissolution is complete. Such samples can then be kept up to six hours before titration.

If samples collected for chemical oxygen demand (COD) analysis cannot be analysed on the day of collection they should be preserved below pH 2 by addition of concentrated sulphuric acid. This procedure should also be followed for samples for ammoniacal nitrogen, total oxidised nitrogen and phenol analysis.

Samples which are to be analysed for the presence of metals, should be acidified to below pH 2 with concentrated nitric acid. Such samples can then be kept up to six months before they need to be analysed; mercury determinations should be carried out within five weeks, however.

After labelling and preservation, the samples should be placed in an insulated cool box for transportation (Figure 3.5). Samples should be transported to concerned laboratory (level II or II+) as soon as possible, preferably within 48 hours.

Analysis of bacteriological samples should be started and analysed within 24 hours of collection.

If samples are being brought to a Level I laboratory for the 'field determinations', they should be transported in less than 24 hours.

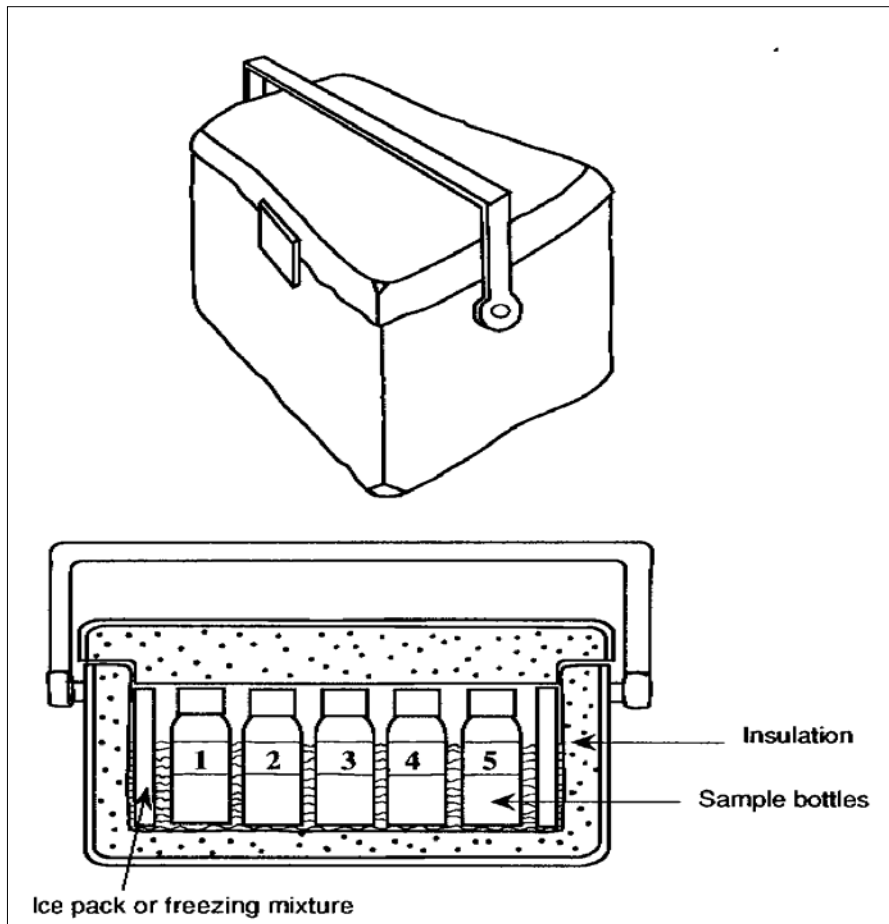

Figure 3.5: Insulated bottle carrier for water quality samples

4 STANDARD ANALYTICAL PROCEDURES – FIELD DETERMINATIONS

4.1 GENERAL

Measurements of colour, odour, temperature, electrical conductivity, pH and dissolved oxygen are considered to be 'Field Determinations' and should be made as soon as possible after collecting a sample.

Measurement of these parameters can be made in the field if field meters are available. This is the best option, as the analyses will be made immediately. Another option is to bring samples to the nearest Level I laboratory, where equipment for analyses is set up. If samples are brought to the level one laboratory, the travel time should be very short, so that parameter values do not change between the time the sample is collected at the time of analysis. Note that the DO sample must be 'fixed' immediately after collection and that the temperature must be measured at the site.

4.2 COLOUR

Determining the colour in the field is relatively easy. Pour an aliquot of approximately 10mL of sample into a glass test tube and judge the colour observed. Assign **one** of the colour codes from Table 4.1 to the sample. In case the colour of water does not fall under code 1 to 7, select code 8 and note down the details of the colour observed. Report the colour code on the sample identification form.

Colour Code	(1) Light brown
	(2) Brown
	(3) Dark brown
	(4) Light green
	(5) Green
	(6) Dark green
	(7) Clear
	(8) Other specify

Table 4.1: Colour codes for field determination of colour

4.3 ODOUR

Determining the odour should always be done in the field, as soon as possible after collecting a sample. After collection, fill a cleaned odourless bottle half-full of sample, insert stopper, shake vigorously for 2-3 seconds and then quickly smell the odour. Alternatively, pour an aliquot of approximately 5 mL of sample into a glass test tube and judge the odour.

Assign **one** of the odour codes from Table 4.2 to the sample. In case option 10 'unpleasant' is selected please try to note down the details of the odour observed (e.g. agreeable or disagreeable). Note: Do not select option 10 if the odour observed can be classified as one in the list from 1 to 9. Report the odour code on the sample identification form.

Odour Code	(1)	Odour free
	(2)	Rotten eggs
	(3)	Burnt sugar
	(4)	Soapy
	(5)	Fishy
	(6)	Septic
	(7)	Aromatic
	(8)	Chlorinous
	(9)	Alcoholic
	(10)	Unpleasant

Table 4.2: Odour codes for field determination of odour

4.4 TEMPERATURE

Water temperature should be measured in degrees Celsius, using a mercury thermometer or a thermistor. Normally, if temperature is measured electronically using a thermistor this device is built into an instrument which is capable of making other water quality measurements (e.g., pH and EC).

Whenever possible, the temperature should be measured by directly dipping the thermometer in the natural body of water being studied. In case it is not possible, collect about 500 mL sample in a plastic or glass container and measure temperature by immersing the thermometer in the sample. Read the temperature after equilibration (no more change in the temperature reading).

Report the Temperature on the sample identification form in degrees Celsius with 1 figure after the decimal point e.g. 13.2 °C.

4.5 ELECTRICAL CONDUCTIVITY

Measurement of Electrical Conductivity should be made in the field at the time of sampling, using a purpose-built meter. Refer to the 'Guideline on Standard Analytical Procedures for Water Analyses' for detailed procedures including preparation of reagents - given in Chapter 5. The procedure is also given below:

- Prepare the instrument following manufacturer's instructions. Rinse conductivity cell with at least three portions of 0.01M KCl solution. Measure resistance of a fourth portion and note temperature.
- In case the instrument indicates conductivity directly, and has internal temperature compensation, after rinsing as above, adjust temperature compensation dial to 0.0191/ °C and with the probe in standard KCl solution, adjust meter to read 1412 µmho/cm. Continue at step d.
- Compute the cell constant, K_C according to the formula:

$$K_C = \frac{1412}{C_{KCl}} \times [0.0191(t - 25) + 1] \quad (4.1)$$

where: K_C = the cell constant, 1/cm
 C_{KCl} = measured conductance, µmho
 t = observed temperature of standard KCl solution, °C

The value of temperature correction $[0.0191 \times (t-25)+1]$ can be read from Table 4.3.

- d. Rinse cell with one or more portions of sample. The level of sample aliquot must be above the vent holes in the cell and no air bubbles must be allowed inside the cell. Adjust the temperature of sample to about 25°C (outside the temperature range of 20 - 30°C, error increases as the sample temperature increasingly deviates from the reporting temperature of 25°C). Read sample conductivity and note temperature to nearest 0.1°C.
- e. Thoroughly rinse the cell in distilled water after measurement; keep it in distilled water when not in use.

Calculation

- a. When sample conductivity is measured with instruments having temperature compensation, the readout automatically is corrected to 25°C. If the instrument does not have internal temperature compensation, conductivity at 25°C is:

$$\text{Electrical Conductivity } (\mu\text{mhos/cm}) = \frac{C_M \times K_C}{0.0191(t - 25) + 1} \quad (4.2)$$

where:

- K_C = the cell constant, 1/cm
 C_M = measured conductance of the sample, μmho
 t = observed temperature of sample, °C

The value of temperature correction $[0.0191 \times (t-25)+1]$ can be read from Table 4.3.

- b. Record the meter reading, the unit of measurement and the temperature of the sample at the time of reading. Report the Electrical Conductivity at 25°C on the sample identification form in $\mu\text{mho/cm}$ with no figures after the decimal point, e.g. 1135 $\mu\text{mho/cm}$.

T (°C)	0.0	0.1	0.2	0.3	0.4	0.5	0.6	0.7	0.8	0.9
15	0.810	0.812	0.814	0.816	0.818	0.820	0.821	0.823	0.825	0.827
16	0.829	0.831	0.833	0.835	0.837	0.839	0.840	0.842	0.844	0.846
17	0.848	0.850	0.852	0.854	0.856	0.858	0.859	0.861	0.863	0.865
18	0.867	0.869	0.871	0.873	0.875	0.877	0.878	0.880	0.882	0.884
19	0.886	0.888	0.890	0.892	0.894	0.896	0.897	0.899	0.901	0.903
20	0.905	0.907	0.909	0.911	0.913	0.915	0.916	0.918	0.920	0.922
21	0.924	0.926	0.928	0.930	0.932	0.934	0.935	0.937	0.939	0.941
22	0.943	0.945	0.947	0.949	0.951	0.953	0.954	0.956	0.958	0.960
23	0.962	0.964	0.966	0.968	0.970	0.972	0.973	0.975	0.977	0.979
24	0.981	0.983	0.985	0.987	0.989	0.991	0.992	0.994	0.996	0.998
25	1.000	1.002	1.004	1.006	1.008	1.010	1.011	1.013	1.015	1.017
26	1.019	1.021	1.023	1.025	1.027	1.029	1.030	1.032	1.034	1.036
27	1.038	1.040	1.042	1.044	1.046	1.048	1.049	1.051	1.053	1.055
28	1.057	1.059	1.061	1.063	1.065	1.067	1.068	1.070	1.072	1.074
29	1.076	1.078	1.080	1.082	1.084	1.086	1.087	1.089	1.091	1.093
30	1.095	1.097	1.099	1.101	1.103	1.105	1.106	1.108	1.110	1.112
31	1.114	1.116	1.118	1.120	1.122	1.124	1.125	1.127	1.129	1.131
32	1.133	1.135	1.137	1.139	1.141	1.143	1.144	1.146	1.148	1.150
33	1.152	1.154	1.156	1.158	1.160	1.162	1.163	1.165	1.167	1.169

Table 4.3: Value of $[0.0191 \times (t-25)+1]$ for Temperature Correction of EC Measurement

4.6 pH

Measurement of pH should be made in the field at the time of sampling, using a purpose-built meter. Follow the procedure below:

- a. Prepare instrument as according to manufacturer's instructions. Remove instrument electrodes from storage solution, rinse with distilled water, blot dry with soft tissue.
- b. First standardisation: Place electrode in initial buffer solution and standardise pH meter to the known pH according to manufacturer's instructions.
- c. Second standardisation: Remove electrodes from the first buffer, rinse thoroughly with distilled water, blot dry and immerse in second buffer preferably of pH within 2 pH units of the pH of the sample. Read pH of the second buffer, which should be within 0.1 unit of the known pH of the buffer.
- d. Determine pH of the sample using the same procedure as in (c) after establishing equilibrium between electrodes and sample. For buffered samples this can be done by dipping the electrode into a portion of the sample for 1 min. Blot dry, immerse in a fresh portion of the same sample, and read pH.
- e. With dilute poorly buffered solutions, equilibrate electrodes by immersing in three or four successive portions of the sample. Take a fresh sample to measure pH.
- f. Stir the sample gently while measuring pH to insure homogeneity.
- g. Report the pH on the sample identification form in pH units with 1 figure after the decimal point, e.g. 7.6.

4.7 DISSOLVED OXYGEN

After the dissolved oxygen sample has been fixed by addition of chemicals (see Chapter 3.6), the sample is analysed by Winkler titration.

Titrate 201 mL sample with standard $\text{Na}_2\text{S}_2\text{O}_3$ (thiosulphate) solution to a pale straw colour. Add a few drops of starch indicator. Continue titration to first disappearance of blue colour. Calculate concentration of dissolved oxygen as:

$$\text{mg DO/L} = \frac{V \times M}{0.025} \quad (4.3)$$

where: V = mL thiosulphate solution used

M = molarity of thiosulphate titrant

Report the Dissolved Oxygen concentration on the sample identification form in mg/l with 1 figure after the decimal point, e.g. 8.2 mg/l.

5 GUIDELINES ON STANDARD ANALYTICAL PROCEDURES

The '*Guidelines on Standard Analytical Procedures for Water Analyses*' for detailed procedures including preparation of reagents are given here for the following analyses:

- Odour
- Temperature
- Electrical Conductivity
- pH
- Dissolved Oxygen

OD	ODOUR
Method:	QUALITATIVE HUMAN RECEPTOR
ID: 1.19	Version: 1

Procedure

- a. As soon as possible after collection of sample, fill a cleaned odourless bottle half - full of sample, insert stopper, shake vigorously for 2 to 3 seconds and then quickly observe the odour. The sample should be at ambient temperature.
- b. Report the odour as: odour free, rotten egg, burnt sugar, soapy, fishy, septic, aromatic, chlorinous, alcoholic odour or any other specific odour. In case it is not possible to specify the exact nature of odour, report as agreeable or disagreeable.

T	TEMPERATURE
Method:	MERCURY THERMOMETER
ID: 1.27	Version: 1

Apparatus

Mercury thermometer having a scale marked for every 0.1°C.

Procedure

- a. Immerse thermometer in the sample up-to the mark specified by the manufacturer and read temperature after equilibration.
- b. When a temperature profile at a number of different depths is required a thermistor with a sufficiently long lead may be used.

Reporting

Report the temperature in units of degree Celsius with 1 figure after the decimal point, e.g. 13.2 °C.

EC	ELECTRICAL CONDUCTIVITY
Method:	CONDUCTIVITY CELL POTENTIOMETRIC
ID: 1.10	Version: 1

Apparatus

- Conductivity meter capable of measuring conductivity with an error not exceeding 1% or 0.1mS/m whichever is greater.
- Conductivity cell, Pt electrode type. For new cells not already coated and old cell giving erratic readings platinise according to the following procedure. Clean the cell with chromic - sulphuric acid cleaning mixture. Prepare platinising solution by dissolving 1g chloroplatinic acid, $H_2PtCl_6 \cdot 6H_2O$ and 12 mg lead acetate in 100 mL distilled water. Immerse electrodes in this solution and connect both to the negative terminal of a 1.5 V dry cell battery (in some meters this source is built in). Connect the positive terminal to a platinum wire and dip wire into the solution. Continue electrolysis until both cell electrodes are coated with platinum black.

Reagent

- Conductivity water - use distilled water boiled shortly before use to minimise CO_2 content. Electrical conductivity must be less than 0.1 $\mu mho/cm$.
- Standard potassium chloride solution, KCl, 0.01M, conductivity 1412 $\mu mho/cm$ at 25 °C. Dissolve 745.6 mg anhydrous KCl (dried 1 hour at 180 °C) in conductivity water and dilute to 1000 mL. This reference solution is suitable when the cell has a constant between 1 and 2 per cm.

Procedure

- Rinse conductivity cell with at least three portions of 0.01M KCl solution. Measure resistance of a fourth portion and note temperature.
- In case the instrument indicates conductivity directly, and has internal temperature compensation, after rinsing as above, adjust temperature compensation dial to 0.0191/ °C and with the probe in standard KCl solution, adjust meter to read 1412 $\mu mho/cm$. continue at step d.
- Compute the cell constant, K_C according to the formula:

$$K_C = \frac{1412}{C_{KCl}} \times [0.0191(t - 25) + 1]$$

where: K_C = the cell constant, 1/cm

C_{KCl} = measured conductance, μmho

t = observed temperature of standard KCl solution, °C

The value of temperature correction $[0.0191 \times (t-25)+1]$ can be read from Table 5.1.

- d. Rinse cell with one or more portions of sample. The level of sample aliquot must be above the vent holes in the cell and no air bubbles must be allowed inside the cell. Adjust the temperature of sample to about 25°C (outside a temperature range of 20 - 30°C, error increases as the sample temperature increasingly deviates from the reporting temperature of 25°C). Read sample conductivity and note temperature to nearest 0.1°C.
- e. Thoroughly rinse the cell in distilled water after measurement, keep it in distilled water when not in use.

Calculation

- a. When sample conductivity is measured with instruments having temperature compensation, the readout automatically is corrected to 25 °C. If the instrument does not have internal temperature compensation, conductivity at 25 °C is:

$$\text{Electrical Conductivity } (\mu\text{mhos/cm}) = \frac{C_M \times K_C}{0.0191(t - 25) + 1}$$

where: K_C = the cell constant, 1/cm

C_M = measured conductance of the sample, μmho

t = observed temperature of sample, °C

The value of temperature correction $[0.0191 \times (t-25)+1]$ can be read from Table 5.1.

- b. Record the meter reading, the unit of measurement and the temperature of the sample at the time of reading. Report the electrical conductivity at 25°C. Report conductivity preferably in $\mu\text{mho/cm}$.

T (°C)	0.0	0.1	0.2	0.3	0.4	0.5	0.6	0.7	0.8	0.9
15	0.810	0.812	0.814	0.816	0.818	0.820	0.821	0.823	0.825	0.827
16	0.829	0.831	0.833	0.835	0.837	0.839	0.840	0.842	0.844	0.846
17	0.848	0.850	0.852	0.854	0.856	0.858	0.859	0.861	0.863	0.865
18	0.867	0.869	0.871	0.873	0.875	0.877	0.878	0.880	0.882	0.884
19	0.886	0.888	0.890	0.892	0.894	0.896	0.897	0.899	0.901	0.903
20	0.905	0.907	0.909	0.911	0.913	0.915	0.916	0.918	0.920	0.922
21	0.924	0.926	0.928	0.930	0.932	0.934	0.935	0.937	0.939	0.941
22	0.943	0.945	0.947	0.949	0.951	0.953	0.954	0.956	0.958	0.960
23	0.962	0.964	0.966	0.968	0.970	0.972	0.973	0.975	0.977	0.979
24	0.981	0.983	0.985	0.987	0.989	0.991	0.992	0.994	0.996	0.998
25	1.000	1.002	1.004	1.006	1.008	1.010	1.011	1.013	1.015	1.017
26	1.019	1.021	1.023	1.025	1.027	1.029	1.030	1.032	1.034	1.036
27	1.038	1.040	1.042	1.044	1.046	1.048	1.049	1.051	1.053	1.055
28	1.057	1.059	1.061	1.063	1.065	1.067	1.068	1.070	1.072	1.074
29	1.076	1.078	1.080	1.082	1.084	1.086	1.087	1.089	1.091	1.093
30	1.095	1.097	1.099	1.101	1.103	1.105	1.106	1.108	1.110	1.112
31	1.114	1.116	1.118	1.120	1.122	1.124	1.125	1.127	1.129	1.131
32	1.133	1.135	1.137	1.139	1.141	1.143	1.144	1.146	1.148	1.150
33	1.152	1.154	1.156	1.158	1.160	1.162	1.163	1.165	1.167	1.169
34	1.171	1.173	1.175	1.177	1.179	1.181	1.182	1.184	1.186	1.188
35	1.190	1.192	1.194	1.196	1.198	1.200	1.201	1.203	1.205	1.207

Table 5.1: Value of $[0.0191 \times (T-25) + 1]$ for Temperature Correction of EC measurement

Multiply	By	to obtain
$\mu\text{S/m}$	0.01	$\mu\text{mho/cm}$
mS/cm	10	$\mu\text{mho/cm}$
mS/cm	1000	$\mu\text{mho/cm}$
$\mu\text{S/cm}$	1	$\mu\text{mho/cm}$
mmho/cm	1000	$\mu\text{mho/cm}$

Table 5.2: Conversion table for units of electrical conductivity

Note

1S = 1mho

Reporting

Report electrical conductivity in units of $\mu\text{mho/cm}$, with 0 digits after the decimal point, e.g. 1135 $\mu\text{mho/cm}$. Use Table 5.2 for conversion of units.

pH	pH
Method:	POTENTIOMETRIC
ID: 1.21	Version: 1

Apparatus

- a. pH meter with temperature compensating device, accurate and reproducible to 0.1 pH unit with a range of 0 to 14.
- b. Reference electrode preferably with quartz liquid junction. Follow manufacturer's instructions on use and care of the reference electrode. Refill non-sealed electrodes with correct electrolyte to proper level and make sure junction is properly wetted.
- c. Follow manufacturer's instructions on use and care of electrode.

Reagents

- a. Potassium hydrogen phthalate buffer, 0.05M, *pH 4.00*. Dissolve 10.12 g $\text{KHC}_8\text{H}_4\text{O}_4$ (potassium hydrogen phthalate) in 1000 mL freshly boiled and cooled distilled water
- b. 0.025M Potassium dihydrogen phosphate + 0.025M disodium hydrogen phosphate buffer, *pH 6.86*. Dissolve 3.387 g KH_2PO_4 + 3.533 g Na_2HPO_4 in 1000 mL freshly boiled and cooled distilled water
- c. 0.01M sodium borate decahydrate (borax buffer), *pH = 9.18*. Dissolve 3.80 g $\text{Na}_2\text{B}_4\text{O}_7 \cdot 10\text{H}_2\text{O}$ in 1000 mL freshly boiled and cooled distilled water.
- d. Store buffer solutions in polyethylene bottles. Replace buffer solutions every 4 weeks.

Procedure

- a. Remove electrodes from storage solution, rinse, blot dry with soft tissue, place in initial buffer solution and standardise pH meter according to manufacturer's instructions.
- b. Remove electrodes from the first buffer, rinse thoroughly with distilled water, blot dry and immerse in second buffer preferably of pH within 2 pH units of the pH of the sample. Read pH, which should be within 0.1 unit of the pH of the second buffer.
- c. Determine pH of the sample using the same procedure as in (b) after establishing equilibrium between electrodes and sample. For buffered samples this can be done by dipping the electrode into a portion of the sample for 1 min. Blot dry, immerse in a fresh portion of the same sample, and read pH.
- d. With dilute poorly buffered solutions, equilibrate electrodes by immersing in three or four successive portions of the sample. Take a fresh sample to measure pH.
- e. Stir the sample gently while measuring pH to insure homogeneity.

Reporting

Report results in pH units with 1 digit after the decimal point, e.g. 7.6.

DO	DISSOLVED OXYGEN
Method:	WINKLER AZIDE MODIFICATION TITRIMETRIC
ID: 1.9	Version: 2

Apparatus

- DO sampler, for collection of undisturbed samples from surface waters.
- BOD bottles, 300 mL, narrow mouth, flared lip, with tapered and pointed ground glass stoppers.
- A siphon tube, for laboratory use.

Reagents

- Manganous sulphate solution. Dissolve 480 g $\text{MnSO}_4 \cdot 4\text{H}_2\text{O}$, 400 g $\text{MnSO}_4 \cdot 2\text{H}_2\text{O}$ or 364 g $\text{MnSO}_4 \cdot \text{H}_2\text{O}$ in distilled water, filter and dilute to IL.
- Alkali-iodide-azide reagent. Dissolve 500 g NaOH (or 700 g KOH) and 135 g NaI (or 150 g KI) in distilled water and dilute to IL. Add 10 g NaN_3 dissolved in 40 mL distilled water.
- Sulphuric acid, conc
- Starch indicator. Dissolve 2 g laboratory grade soluble starch and 0.2 g salicylic acid as a preservative, in 100 mL hot distilled water.
- Standard sodium thiosulphate titrant, 0.025M (0.025N). Dissolve 6.205 g $\text{Na}_2\text{S}_2\text{O}_3 \cdot 5\text{H}_2\text{O}$ in distilled water. Add 1.5 mL 6N NaOH or 0.4 g solid NaOH and dilute to 1000 mL. Standardise with bi-iodate solution.
- Standard potassium bi-iodate solution, 0.0021M (0.0126N), Dissolve 812.4 mg $\text{KH}(\text{IO}_3)_2$ in distilled water and dilute to 1000 mL.
- Standardisation: Take 100 to 150 mL distilled water in an Erlenmeyer flask. Add approximately 2g KI, dissolve. Add 1 mL 6N H_2SO_4 or a few drops of conc H_2SO_4 and 20 mL bi-iodate solution. Dilute to 200 mL and titrate liberated iodine with thiosulphate titrant to a pale straw colour. Add a few drops of starch indicator. Continue titration to first disappearance of blue colour. Calculate molarity, M of thiosulphate as:

$$M = \frac{20 \times 0.025}{V}$$

where: V = mL of thiosulphate used

Procedure

- Drain any liquid in the flared lip of the BOD bottle containing the sample.

- b. Remove stopper and add 1 mL of MnSO_4 followed by 1 mL alkali-iodide-azide reagent. Hold the pipette tip just below the liquid surface touching the side of the bottle. Wash the pipette before returning to the reagent bottles.
- c. Stopper carefully to exclude air bubbles. Mix by inverting the bottle a few times.
- d. Allow the brown manganese hydroxide floc (white floc indicates absence of DO) to settle approximately to half the bottle volume, add 1.0 mL conc H_2SO_4 and re-stopper. Mix by inverting several times until dissolution is complete.
- e. Titrate 201 mL sample with standard $\text{Na}_2\text{S}_2\text{O}_3$ as for standardisation procedure described above.

Calculation

$$\text{mg DO/L} = \frac{V \times M}{0.025}$$

where: V = mL thiosulphate solution used
 M = molarity of thiosulphate titrant

Reporting

Report dissolved oxygen in units of mg/L with 1 digit after the decimal point, e.g. 8.2 mg/L.